

Performance Series



Quality Assurance

Woodside Industries has over 19 years of experience in manufacturing and finishing custom cabinetry and countertops for a range of commercial, industrial and construction clients.

We are a member of the Architectural Woodworking Institute's Quality Certification Program (QCP) on laminate and wood cabinetry.



Our passion is creating high quality finished products that exceed the expectations of our customers.

Even after installation is complete we are committed to our products and stand behind our workmanship to guarantee our customers satisfaction.

Our custom solution services for any industry include, but aren't limited to, commercial cabinetry, architectural millwork and trim, industrial casework or institutional casework, dental and medical grade cabinets and countertops, display cases, custom office furniture, custom office desks, and many more custom build solution services.



Project Gallery



Cabinet Construction

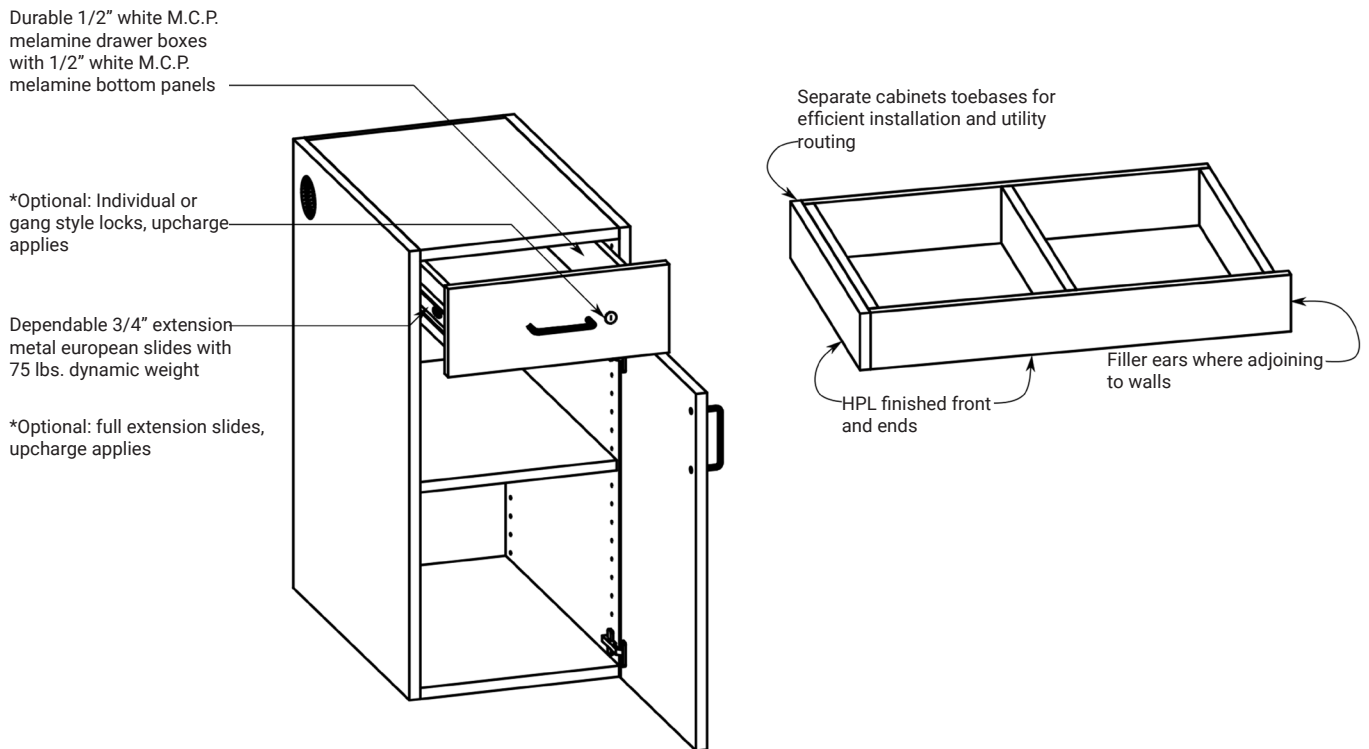
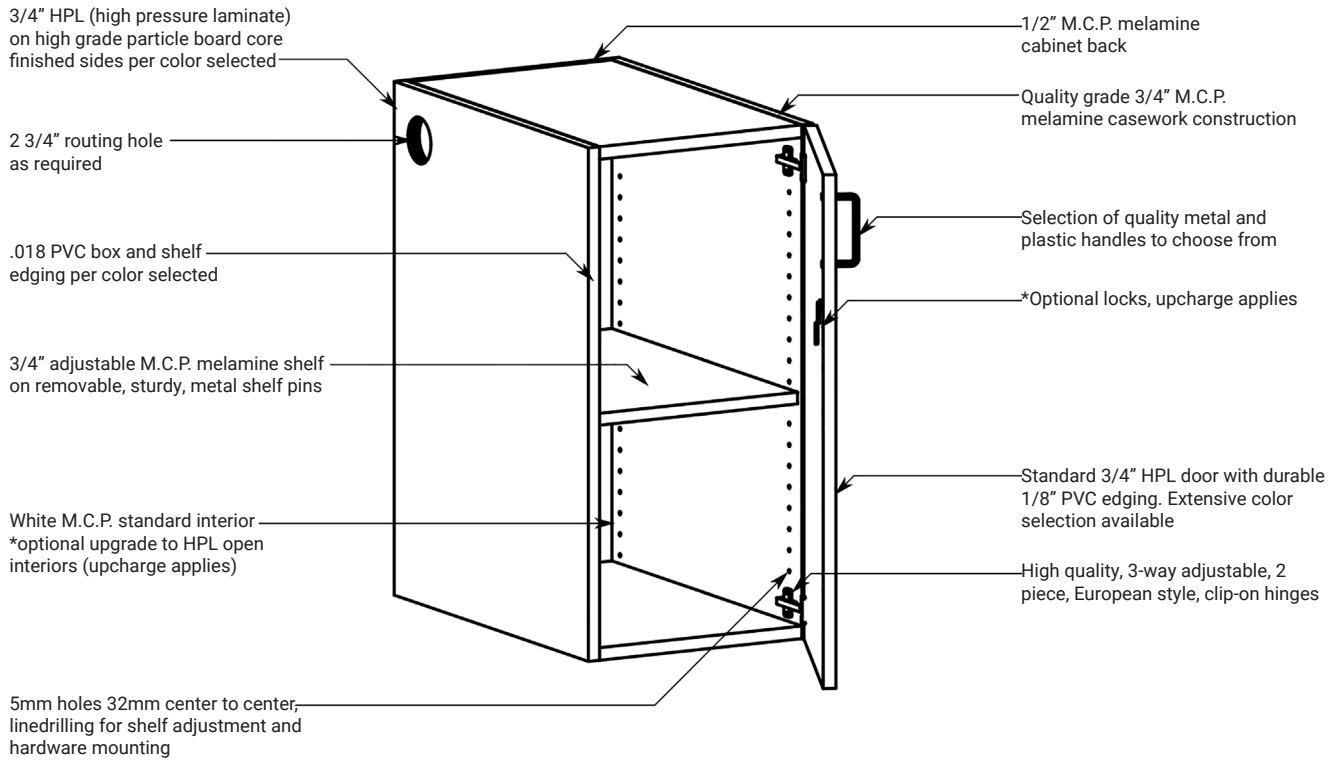

Base Cabinets

36" COUNTER HEIGHT
30 1/2" CASE HEIGHT
24" CASE DEPTH

PRODUCT NUMBER: 24 B 36 24

WIDTH
TYPE
DEPTH
HEIGHT

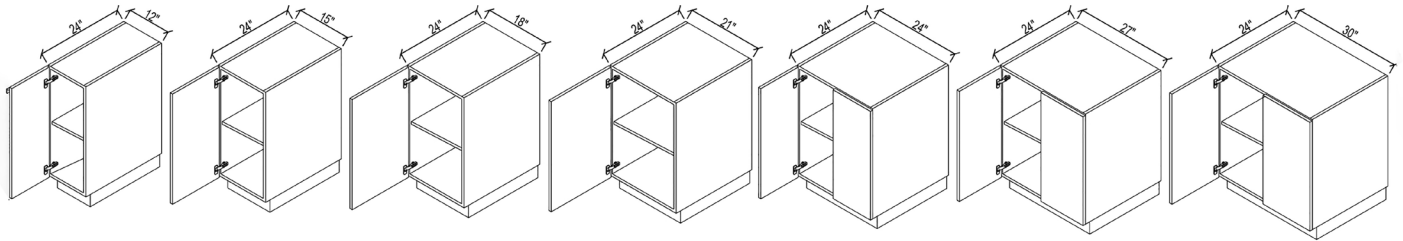

12B3624

15B3624

18B3624

21B3624

24B3624

27B3624

30B3624

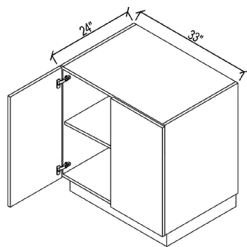

33B3624

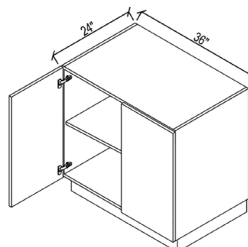

36B3624

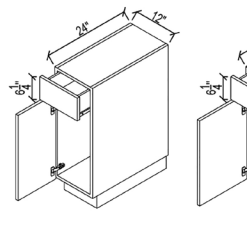

12DB3624

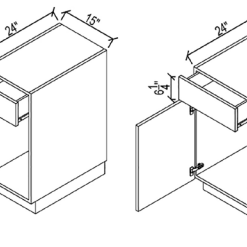

15DB3624

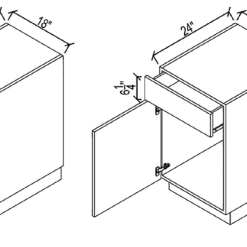

18DB3624



21DB3624

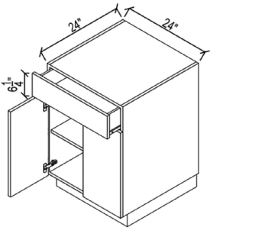

24DB3624

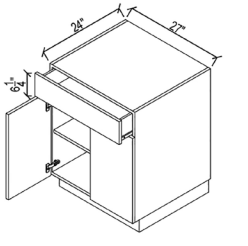

27DB3624

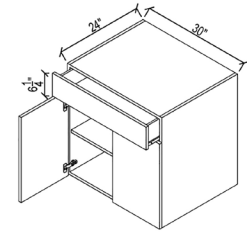

30DB3624

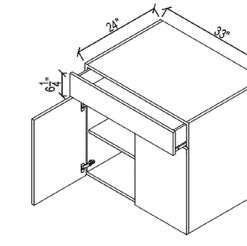

33DB3624

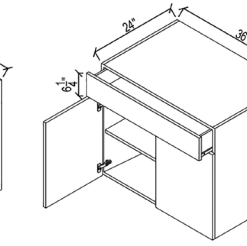

36DB3624

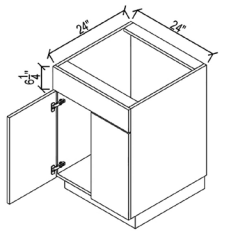

24FSB3624

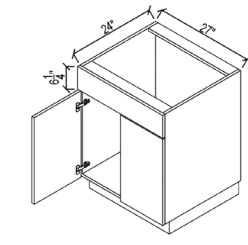

27FSB3624

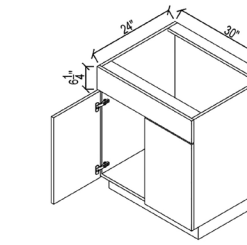

30FSB3624

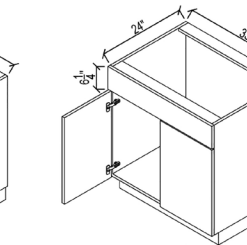

33FSB3624

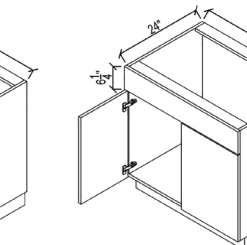

36FSB3624

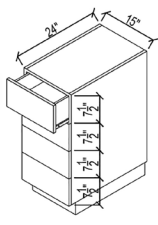

15D4B3624

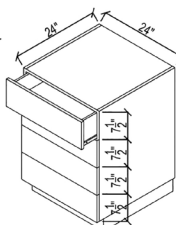

24D4B3624

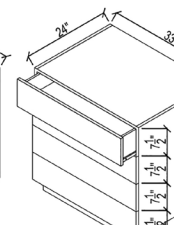

33D4B3624

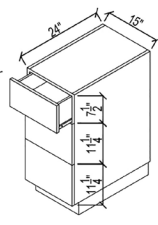

15D3B3624

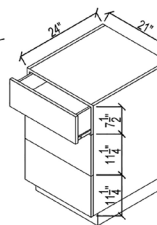

21D3B3624

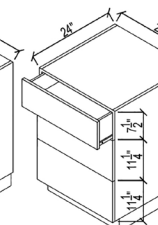

24D3B3624

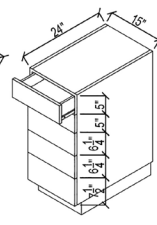

15D5B3624

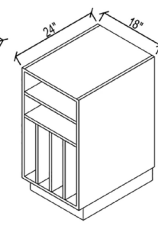

18OB3624

Base & Utility Cabinets

30" COUNTER HEIGHT
24 1/2" CASE HEIGHT
24" CASE DEPTH

PRODUCT NUMBER: 24 B 30 24

WIDTH
TYPE
DEPTH
HEIGHT

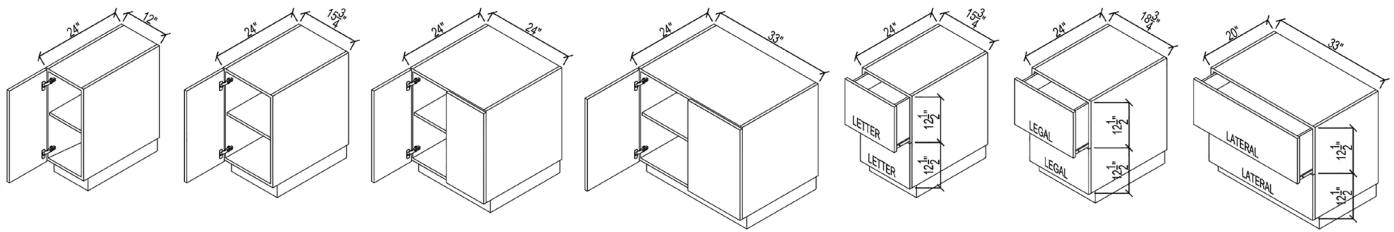

12SB3024

16SB3024

24SB3024

33SB3024

16FB3024

19FB3024

33FB3020

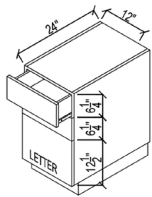

16DFB3024

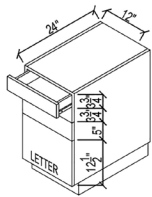

16PFB3024

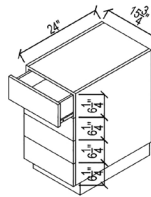

16DB3024

SPECIAL PURPOSE UTILITY CABINETS

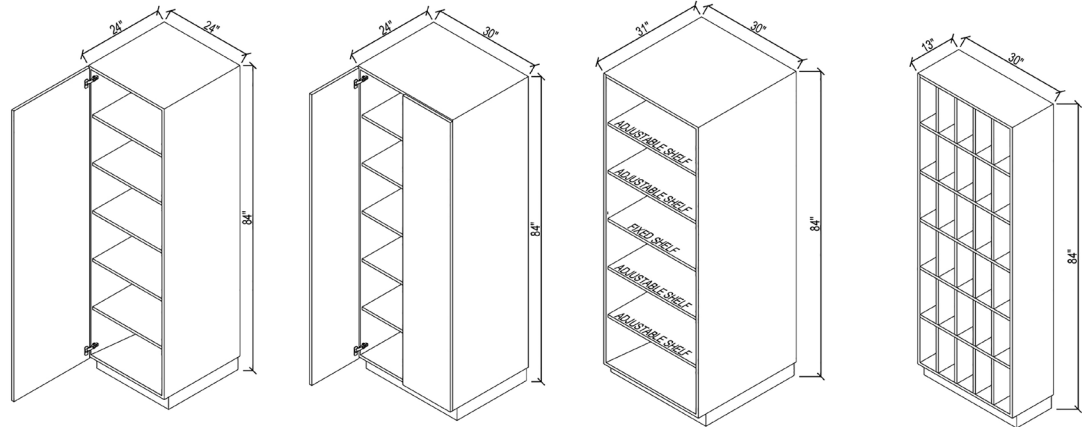

24TC8424

30TC8424

30 OTC 8431

30 OTC 8413

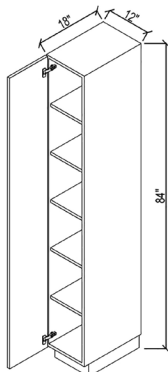

12 TC 8418

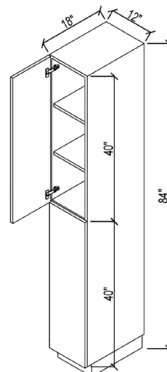

12 TC 8418 H

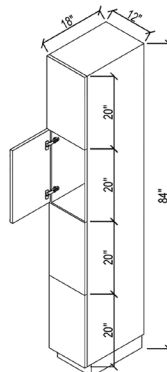

12 TC 8418 3H

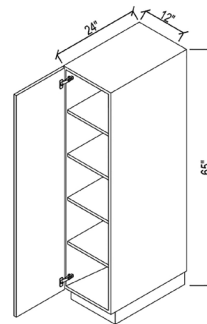

12 TC 6524

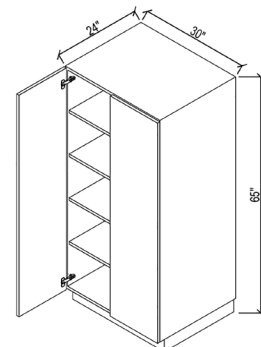

30 TC 6524

Wall Cabinets

WALL CABINETS 18" CASE HEIGHT 13" CASE DEPTH

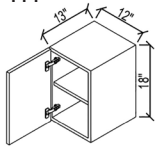

12W18

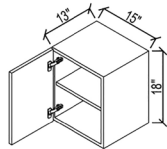

15W18

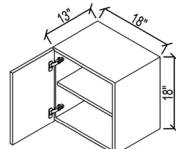

18W18

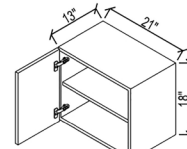

21W18

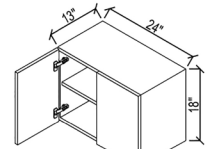

24W18

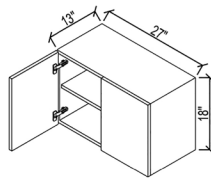

27W18

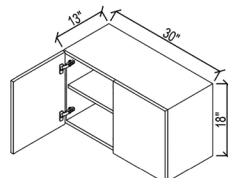

30W18

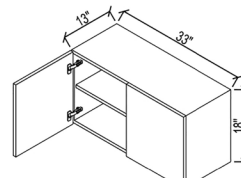

33W18

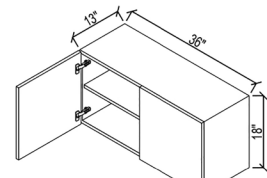

36W18

WALL CABINETS 24" CASE HEIGHT 13" CASE DEPTH

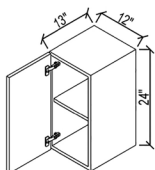

12W24

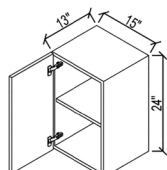

15W24

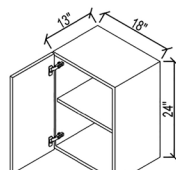

18W24

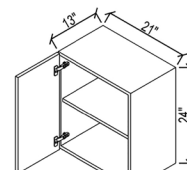

21W24

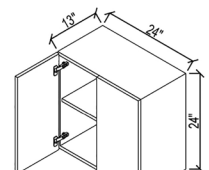

24W24

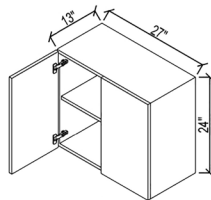

27W24

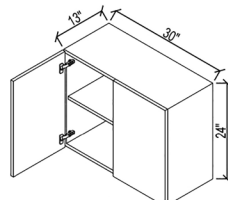

30W24

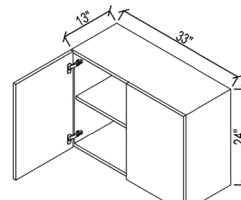

33W24

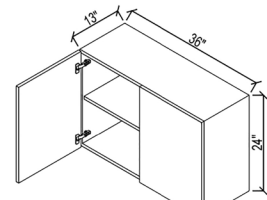

36W24

WALL CABINETS 30" CASE HEIGHT 13" CASE DEPTH

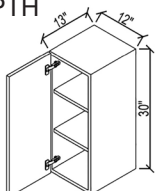

12W30

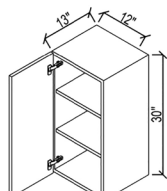

15W30

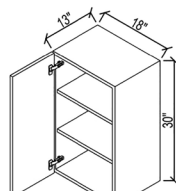

18W30

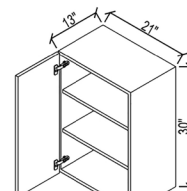

21W30

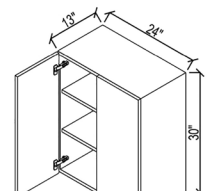

24W30

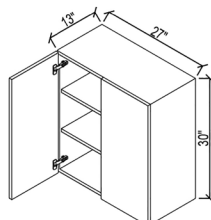

27W30

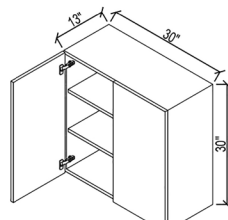

30W30

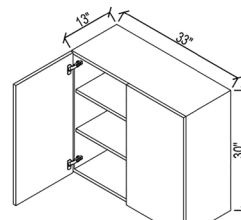

33W30

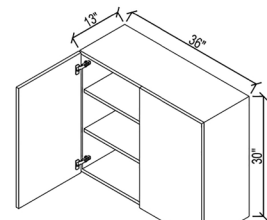

36W30

Wall Cabinets

WALL CABINETS 36" CASE HEIGHT 13" CASE DEPTH

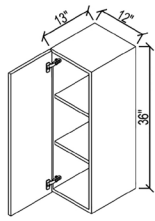

12W36

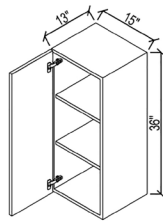

15W36

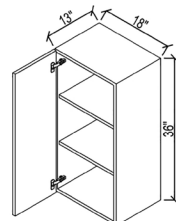

18W36

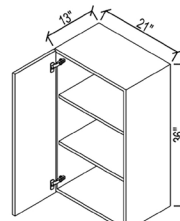

21W36

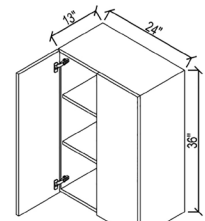

24W36

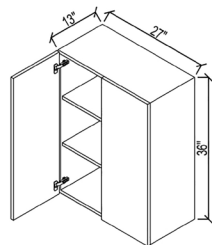

27W36

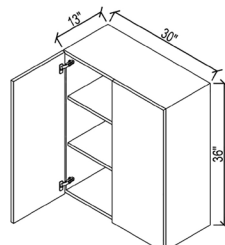

30W36

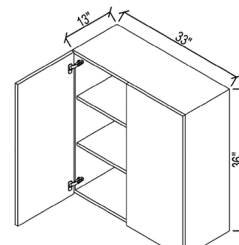

33W36

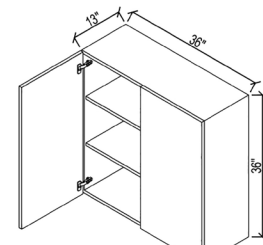

36W36

WALL CABINETS 42" CASE HEIGHT 13" CASE DEPTH

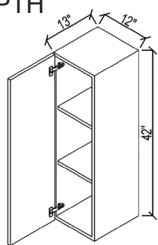

12W42

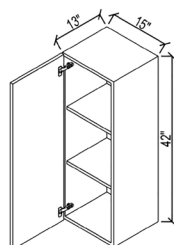

15W42

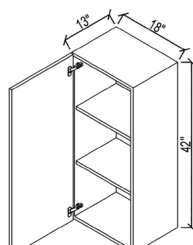

18W42

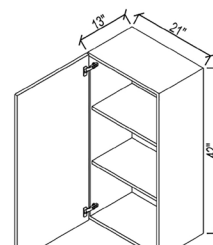

21W42

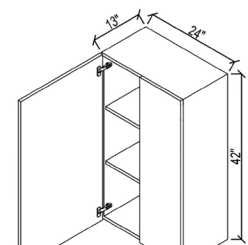

24W42

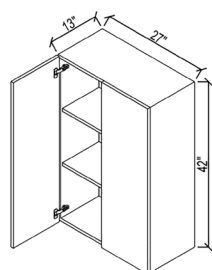

27W42

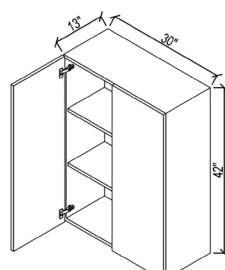

30W42

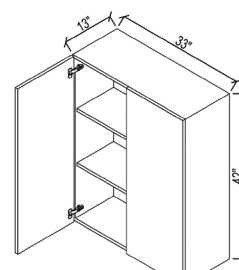

33W42

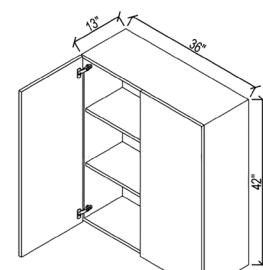

36W42

WALL CABINETS ABOVE REFRIGERATOR 24" CASE DEPTH

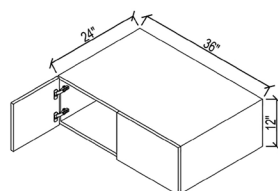

36W12

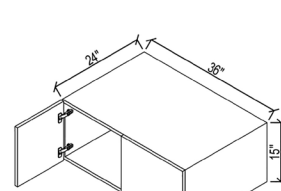

36W15

Special Purpose Cabinets

SPECIAL PURPOSE WALL CABINETS

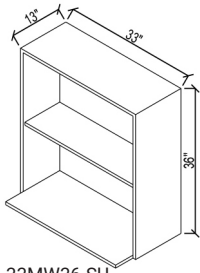

33MW36-SU

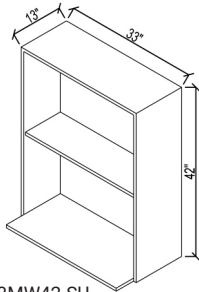

33MW42-SU

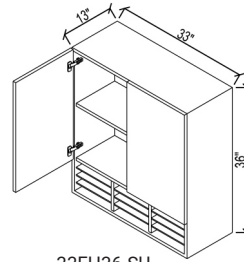

33FH36-SU

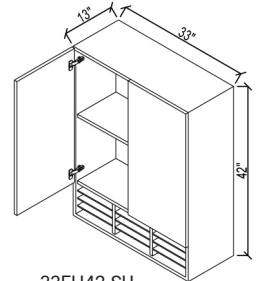

33FH42-SU

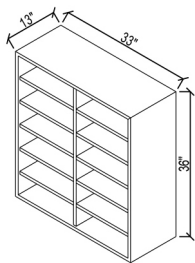

33MS36-SU

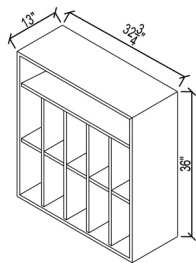

33LSF36-SU

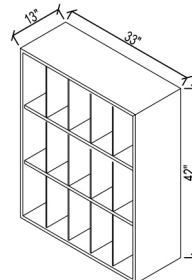

33LSF42-SU

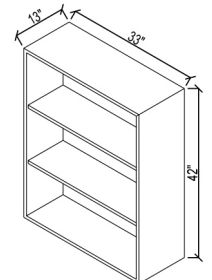

33BK42

BOOKCASES AND STORAGE

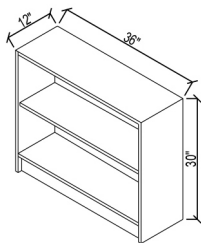

3630SB

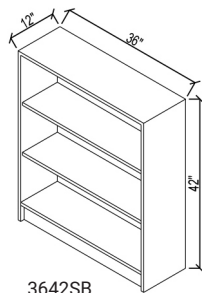

3642SB

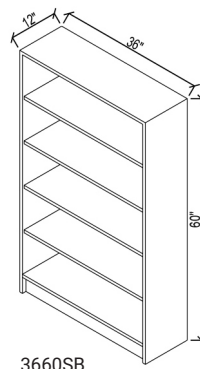

3660SB

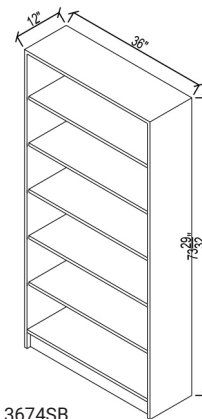

3674SB

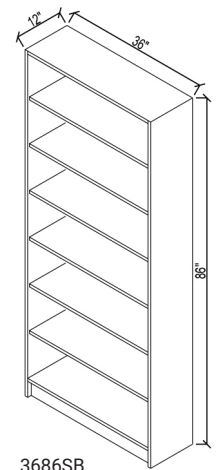

3686SB

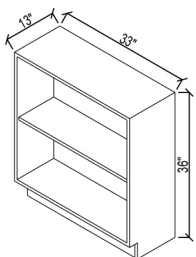

32BK36

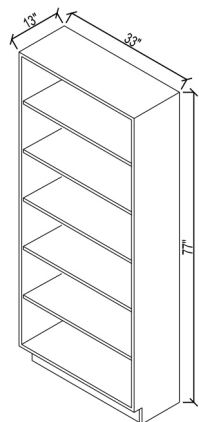

32BK77

Hutches & Desk Systems

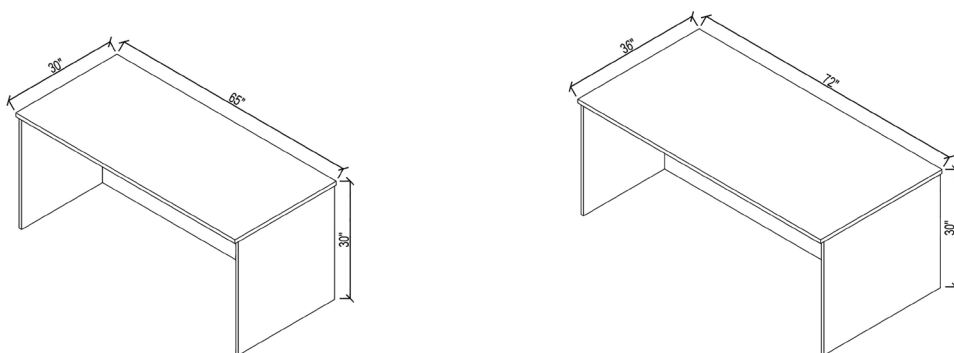
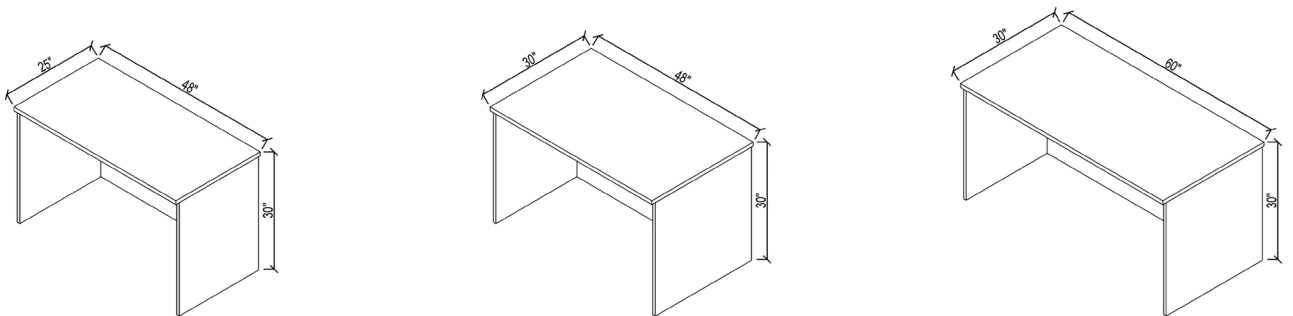
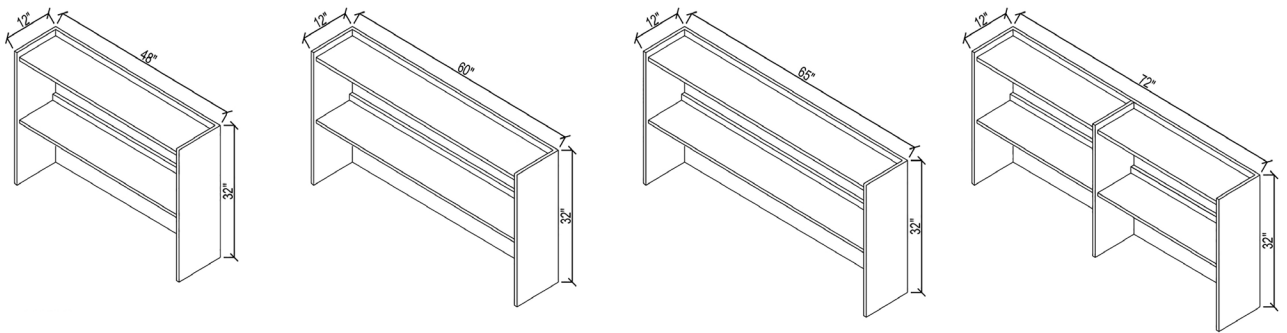
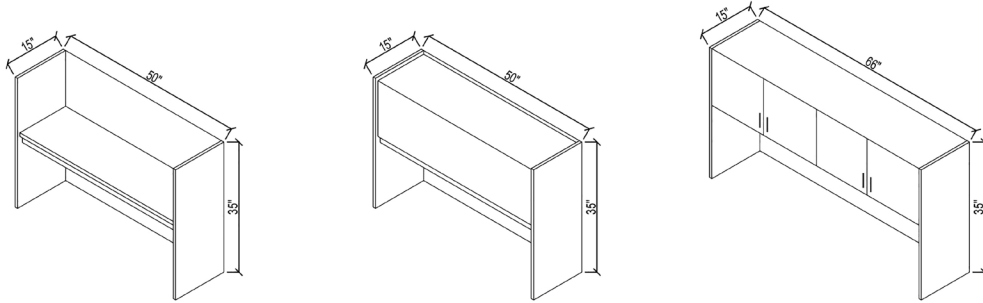

File Cabinets

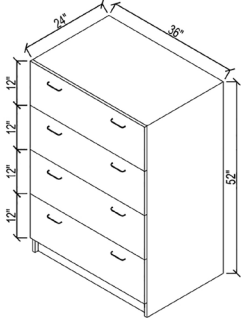
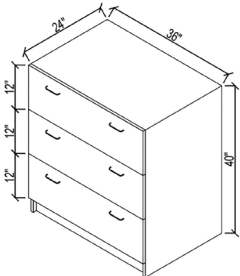
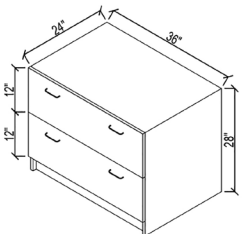
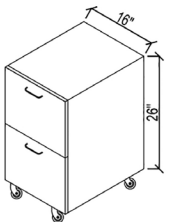
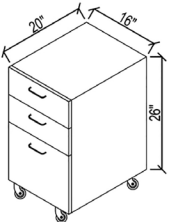
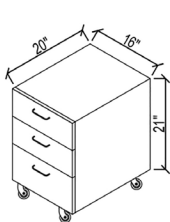

CREATE YOUR PERFECT
WORK SPACE CONFIGURATION

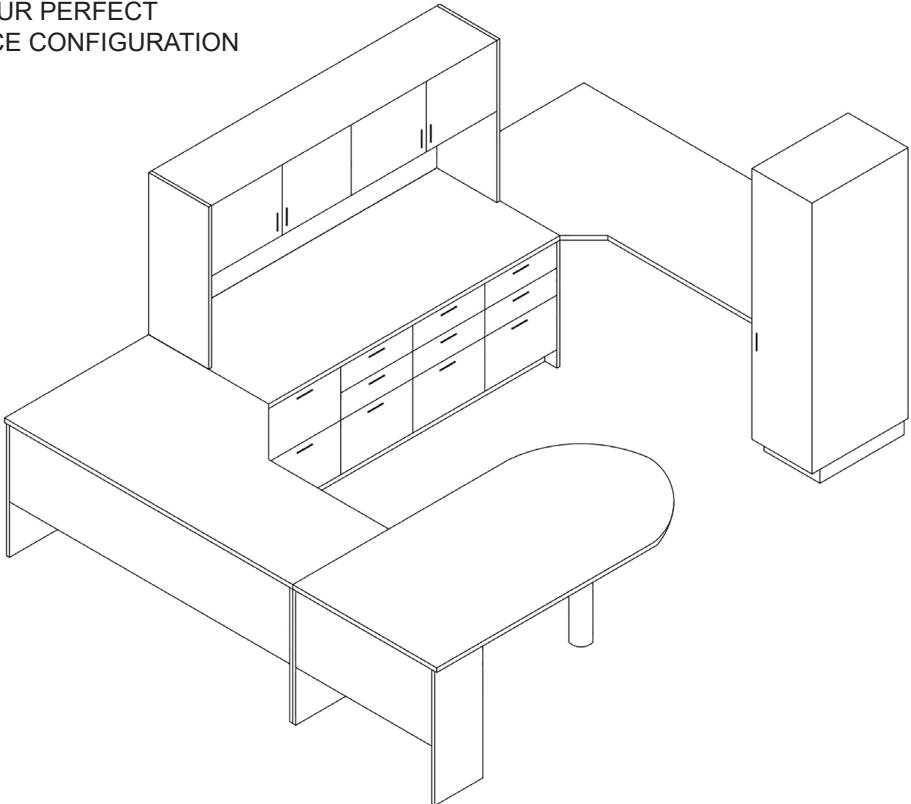



Cavalier, ND - Main Office
Phone: 701-265-8212
Email: rodney@woodsideind.com

Kalispell, MT Office
Phone: 406-756-9880
Email: dwayne@woodsideind.com

Burnsville, MN Office
Phone: 833-966-3463
Email: greg@woodsideind.com